

arktik® 2000P

DESIGNED AND DEVELOPED TO MEET THE NEEDS OF MOBILE FREEZER COOLROOMS

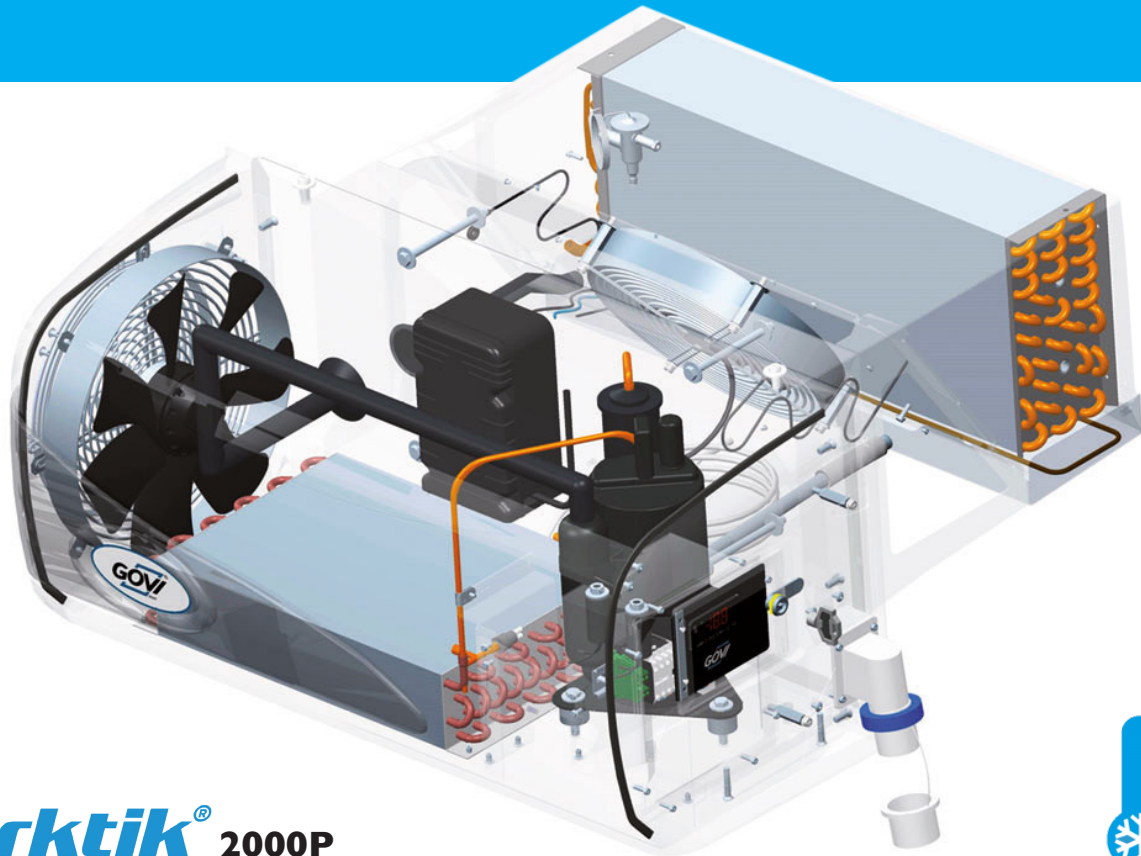

arktik® 2000P



Equipment

- CFC-free refrigerant R452A, GWP 2141
- Digital touch screen thermostat
- Water-resistant lockable control panel
- Suction line cooled compressor
- Automatic hot gas defrosting
- Weatherproof electrical plug and socket
- Pre-wired cable to connect door contact switch
- Pre-wired cable to connect light
- Oval wall light and light bulb

Feature

- Eco-friendly CFC-free refrigerant, minimum energy consumption
- Plug & play installation – easy handling, excellent usability
- Premium-quality, German engineering
- Weather-resistant, robust construction
- Bluetooth module available
- Reliable and quiet operation
- Low maintenance
- Low weight
- Elegant, timeless design

Warranty

- 24-month warranty
- First 12-months warranty on parts and labour
- Additional 12 months on parts only
- Fast spare parts' selection and immediate delivery

GOVI[®]
GmbH



Meeting Market Needs

- Factory finished product
- Easy fast installation
- Light weight and compact
- Cost effective
- Long life & low operating expenses
- Dynamic range cooling capacity
- 7 amps - plugs in anywhere
- One-piece - small interior footprint
- Consistent product quality
- Easy & safe to own & operate
- Easy to maintain & service
- Professionally finished product
- Powerful & reliable unit

Technical Date 2000P

Temperature range	-20 to 10 °C	Defrosting	1090 W
Max operating temperature	40 °C	Air flow evaporator	1100 m³/h
Max volume trailer	10 m³	Air flow condenser	1100 m³/h
Power supply	230 V	Protection class, mounting side	54 IP
Frequency	50 Hz	Refrigerant	R452a
Cooling capacity	1500/2050 W	Refrigerant quantity	1170 g
Power consumption	1000/1200 W	Weight	63 kg
Current consumption LRA	32 A	Colour	9010 RAL
Current consumption FLA	6.5/7.0 A		

The data indicated refers to a set temperature of 2°C / -20 °C • Refrigeration is based on the following operating conditions: outside temperature 30 °C, RH 50% • Insulation with a k-value of 0.2 W/m²K is recommended.

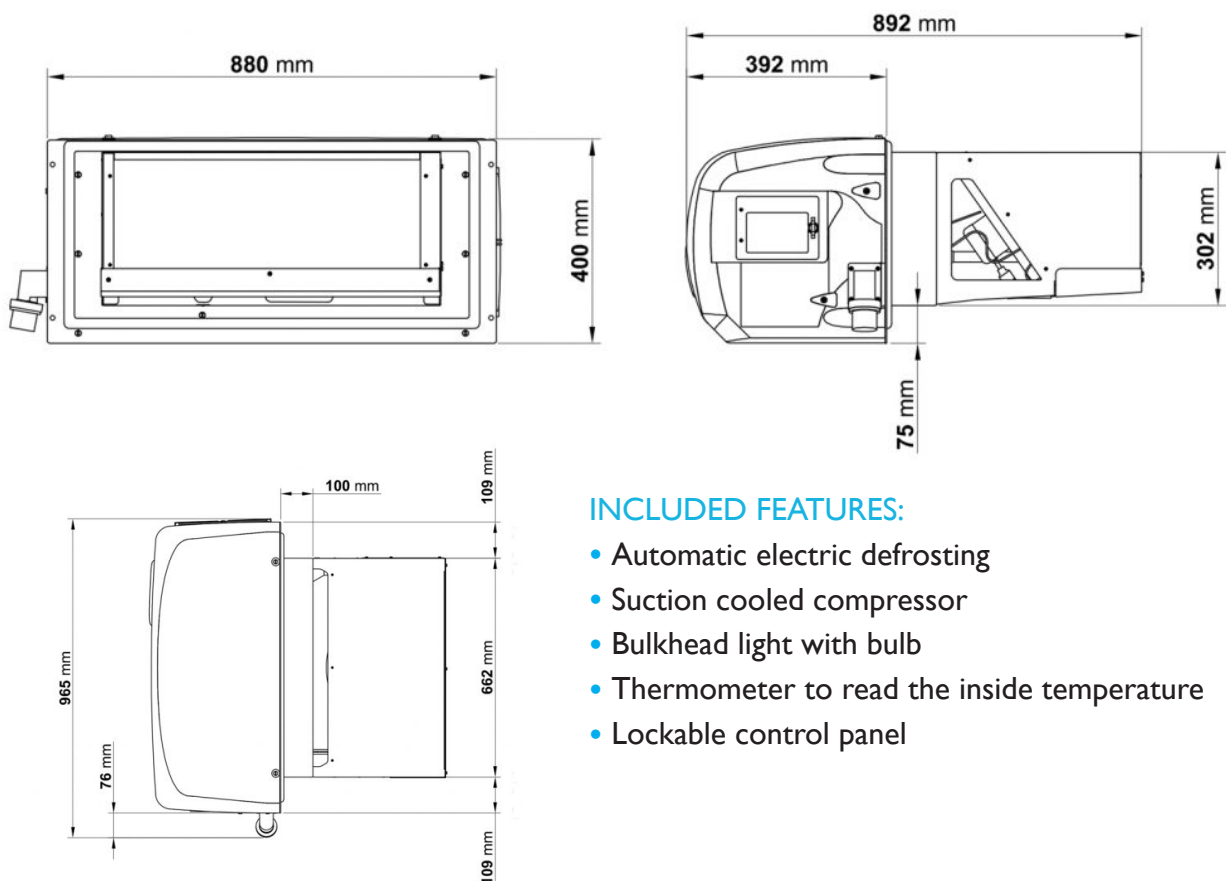

INCLUDED FEATURES:

- Automatic electric defrosting
- Suction cooled compressor
- Bulkhead light with bulb
- Thermometer to read the inside temperature
- Lockable control panel