

arktik® 4000N

DESIGNED AND DEVELOPED TO MEET THE NEEDS OF CONTAINER AND MOBILE COOLROOM REFRIGERATION

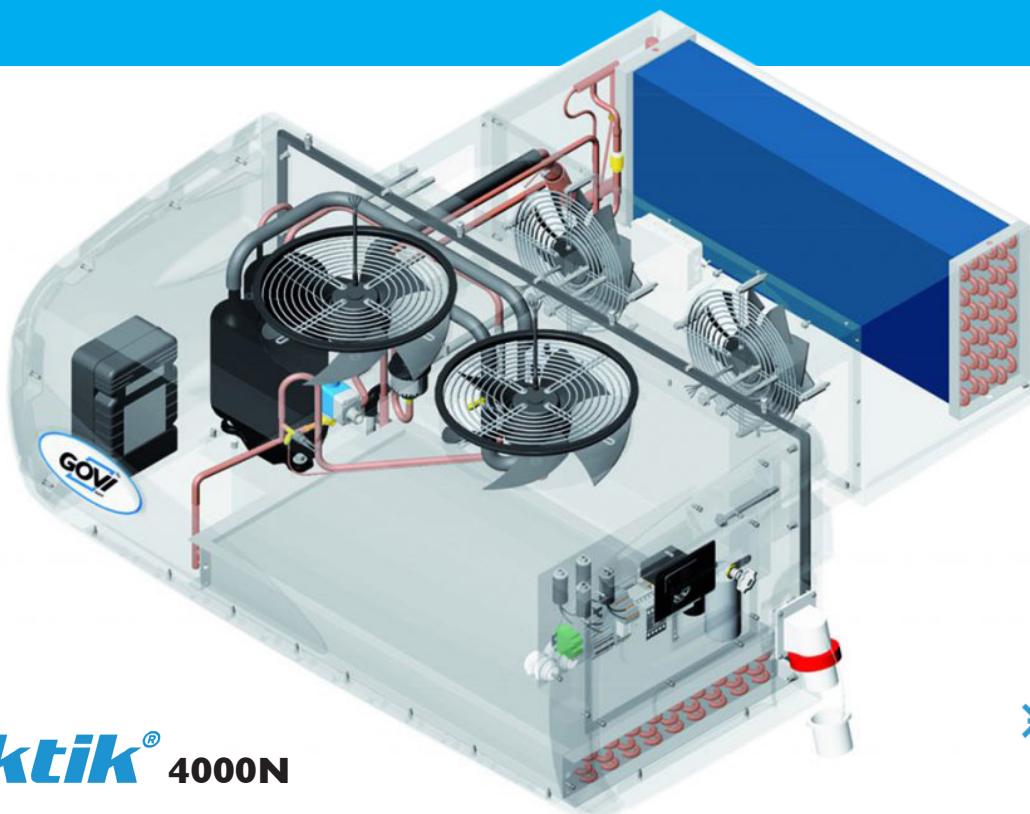

arktik® 4000N

Equipment

- CFC-free refrigerant R452A, GWP 2141
- Digital touch screen thermostat
- Water-resistant lockable control panel
- Suction line cooled compressor
- Automatic hot gas defrosting
- Weatherproof electrical plug and socket
- Pre-wired cable to connect the light inside the trailer

Feature

- Eco-friendly CFC-free refrigerant, minimal energy consumption
- Plug & play installation – easy handling, excellent usability
- Premium-quality, German engineering
- Weather-resistant, robust construction
- Bluetooth module available
- Reliable and quiet operation
- Low maintenance
- Low weight
- Elegant and timeless design

Warranty

- 24-month warranty
 - First 12-months warranty on parts and labour
 - Additional 12 months on parts only
 - Fast spare parts' selection and immediate delivery





Meeting Market Needs

- Factory finished product
- Easy fast installation
- Light weight and compact
- Cost effective
- Long life & low operating expenses
- Dynamic range cooling capacity
- One-piece - small interior footprint
- Consistent product quality
- Easy & safe to own & operate
- Easy to maintain & service
- Professionally finished product
- Powerful & reliable unit
- Silent operation

Technical Date 4000N

Temperature range	2 to 10 °C	Defrosting	Hot gas W
Max operating temperature	40 °C	Air flow evaporator	3270 m³/h
Max volume trailer	32 m³	Air flow condenser	4200 m³/h
Power supply	400/3~V	Protection class, mounting side	54 IP
Frequency	50 Hz	Refrigerant	R452a
Cooling capacity	4050 W	Refrigerant quantity	1700 g
Power consumption	2850 W	Weight	163 kg
Current consumption LRA	54 A	Colour	9010 RAL
Current consumption FLA	12 A		

The data indicated refers to a set temperature of 2 °C • Refrigeration is based on the following operating conditions: outside temperature 30 °C, RH 50% • Insulation with a k-value of 0.2 W/m²K is recommended.

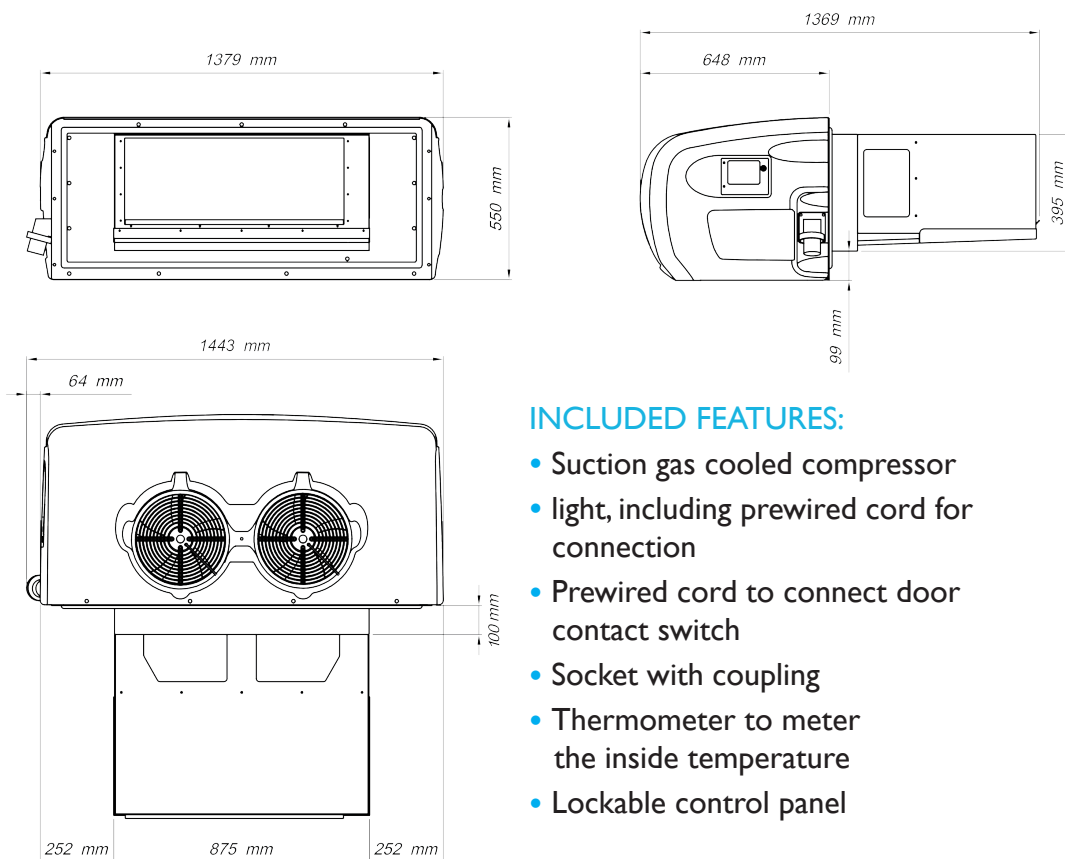

INCLUDED FEATURES:

- Suction gas cooled compressor
- light, including prewired cord for connection
- Prewired cord to connect door contact switch
- Socket with coupling
- Thermometer to meter the inside temperature
- Lockable control panel